

# Lighting *Answers*

## Task Lighting for Offices

Volume 1 Number 3

April 1994

NATIONAL  
LIGHTING  
PRODUCT  
INFORMATION  
PROGRAM

### Introduction

In offices, most efforts to reduce lighting energy costs have focused on maximizing the efficiency of the general (or ambient) lighting system. The common approaches include installing energy-efficient lamps, electronic ballasts, specular reflectors, and occupancy sensors. Relatively little attention has been paid to the potential for energy savings that the effective use of task lighting offers. Task lighting can provide illumination where it is most needed—on the work surface—more economically than the most energy-efficient ceiling luminaire (light fixture), simply because task lighting is located closer to the work surface. When retrofitting the lighting in an office, the general *illuminance*\* can be reduced if task lighting is implemented properly into the overall design. The result can be significant energy savings and improved visibility for workers. However, used improperly, task lighting can result in wasted energy and poorer visibility.

Although for many people the term task lighting conjures up the image of a portable desk lamp, products that are mounted under shelves or cabinets attached to office partitions are the most common type of task lighting used in offices today. One furniture manufacturer reports that approximately one-third of all American office workers occupy partitioned workstations, and under-shelf products account for approximately 90 percent of all office task lighting sold. This issue of *Lighting Answers* examines under-shelf and portable task lighting and explains how to use task lighting effectively to save energy and improve visibility.

\* All terms in *italics* are defined in the glossary on p. 7.

### How much light is needed in an office?

The Illuminating Engineering Society of North America (IESNA) has established a procedure for determining how much illuminance is needed for a given task. The procedure takes into account several factors, including the type of activity, the characteristics of the visual task, the age of the person performing the task, how critical speed and accuracy are, and the reflectance of the task's background.

The procedure categorizes tasks by how difficult they are to see. Small print tasks and low-contrast tasks fall into higher illuminance categories. Office tasks such as reading telephone books, maps, or handwritten notes in No. 3 pencil fall into category "E," where three desk-height illuminances are suggested: 50, 75, or 100 footcandles (abbreviated fc; metric equivalents 500, 750, or 1000 lux). In most cases, the middle value is used. The lower value should be used when at least two of the following are true: the office occupants are all under 40; speed and accuracy are not important; or the reflectance of the background is high (white paper, for example). The higher value should be used if at least two of the following are true: the office occupants are over 55; speed and accuracy are critical (in accounting, for example); or the reflectance of the task background is low (dark grey paper, for example).

Most office workers perform a variety of visual tasks. The illuminance should be sufficient to facilitate the most difficult visual task performed. Thus, if workers spend part of the day reading category "D" materials such as typed originals or first-generation photocopies, which would require only 20, 30 or 50 fc (200, 300 or 500 lux), and part of the day reading poor fax copies, category "E" illuminance should be provided.

In a typical office, the general lighting often is designed to provide an illuminance of 75 fc (750 lux) at desk height, the middle value from category “E.” In partitioned workspaces, it is difficult for general lighting to deliver this illuminance to the desk surfaces, because shadows from shelves, cabinets, partitions, and the worker’s own body can block light from the ceiling-mounted luminaires.

### Can task lighting provide the necessary illuminance more efficiently than general lighting?

Yes. Rather than providing a high general illuminance all the time, task lighting can be used to provide the additional light where it is needed on the desk, and only when the difficult task is being performed. Task lighting provides illuminance more efficiently than general lighting because it is closer to the work surface.

For example, in an office that requires 75 fc (750 lux), a fluorescent under-shelf task light can provide 40 fc (400 lux), which allows the general lighting to be reduced to 35 fc (350 lux). Even greater energy savings can be achieved if the task lights are switched off when not in use.

Task lighting can **increase** the energy use in an office if the general illuminance is not reduced when task lighting is added. Thus, task lighting should be carefully selected and implemented as an integral part of an office lighting system for either retrofit or new construction projects.

### How can visibility problems with task lighting be avoided?

Proper illuminance is achieved easily with task lighting. However, there are other visibility problems that can result from using task lighting, including reflected glare, veiling reflections, direct glare, and extreme differences in brightness in a workstation.

Reflected glare is the reflected image of a bright light source from a specular (shiny) surface, such as a polished desktop or a glossy magazine. Veiling reflections occur when reflected light obscures the task by reducing its contrast. For example, light from a bright luminaire reflected from thermal fax paper can make the whole page (both the print and the background) so bright that it is difficult to read.

Both reflected glare and veiling reflections can be minimized by locating luminaires away from the offending zone (the geometry of the offending zone is illustrated in Figure 1). The offending zone for a worker looking at materials on a desk is immediately in front of the worker. Nevertheless, this often is where task lights are located. To reduce reflected glare and veiling reflections, the light that exits a luminaire in the offending zone should be masked or redirected. The best solution is lighting that is directed toward the task from either or both sides.

Direct glare occurs when a bright light source is within the field of view of an observer. A task light can be a source of direct glare if its lamp or lens is visible from the normal viewing position of either the workstation occupant or workers nearby. Mounting a task light above the eye height of the worker can cause direct glare. A good task lighting system is shielded from direct view by opaque material, either built into the task light itself or as part of the shelf to which it is mounted. Figure 2 shows examples of both a properly shielded task light and a task light mounted in a position that causes direct glare. Reflected glare, veiling reflections, and direct glare can hamper visibility and worker productivity. Complaints of eyestrain and headaches sometimes are attributed to these problems.

Figure 1  
How a task light can create reflected glare and veiling reflections

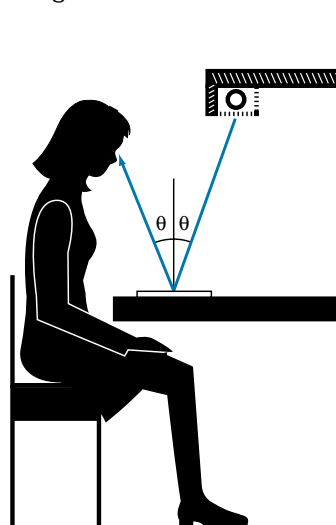

The image of a bright lamp under the shelf can be reflected from a specular task or desktop directly into the worker’s eyes. Light that strikes a task at angles that reflect directly into a worker’s eyes (such as angle  $\theta$ ) can create a veiling reflection that makes the print difficult to read. Optics built into the task light can minimize reflected glare and veiling reflections by redirecting the light so that it is not cast forward toward the worker at these angles.

Extreme variations in brightness at a workstation, or strong patterns of light on the work surface, also can be a source of eyestrain or distraction. An ideal task lighting system produces relatively uniform illuminance on the work surfaces. As a rough guideline, the highest illuminance on the work surface should be no greater than three times the lowest.

### What types of under-shelf luminaires are available?

Under-shelf luminaires usually are purchased as accessories to office furniture. They frequently are supplied by the office furniture manufacturer, but also are available from lighting equipment manufacturers. These products can be divided into the following five categories, which are arranged roughly from worst to best in terms of producing uniform illuminance and avoiding reflected glare and veiling reflections. Most under-shelf luminaires use fluorescent lamps. The luminaires in categories 1, 2, 4, and 5 use linear fluorescent lamps, typically a 3- or 4-foot T12 or T8 lamp. Luminaires in category 3 use compact fluorescent lamps.

**1. Luminaires that do not mask or redirect light.** These include bare fluorescent lamp striplights, and striplights with either a *prismatic lens* or diffuser, as shown in Figure 2b. These luminaires produce reflected glare and veiling reflections, in addition to direct glare.

**2. Luminaires that mask light.** This category includes luminaires that use a fixed opaque shield to block light at offending angles (see Figure 2a) and products that can be adjusted to partially block the light in any direction. An example of an adjustable product is a striplight with a rotatable plastic sleeve on the fluorescent tube. A gradient pattern of black dots on the clear sleeve is used to mask the light. Because the effectiveness of this product depends on proper adjustment of the rotating sleeve, workers should be shown how to use it appropriately.

**3. Luminaires with a small light source using asymmetrical optical control.** These luminaires use a compact fluorescent lamp and an asymmetrically shaped reflector that directs most of the light in one direction. They usually are located in pairs above the principal work surface, one at each end of the shelf. If the worker is positioned halfway between the two luminaires, veiling reflections are minimized because the light is aimed toward the task from the sides. If only one is used, it can create strong shadows on the task from three-dimensional objects such as the worker's hand. These luminaires may cast distinct streaks of light on the partition, which may be distracting.

Figure 2  
How a task light can create direct glare

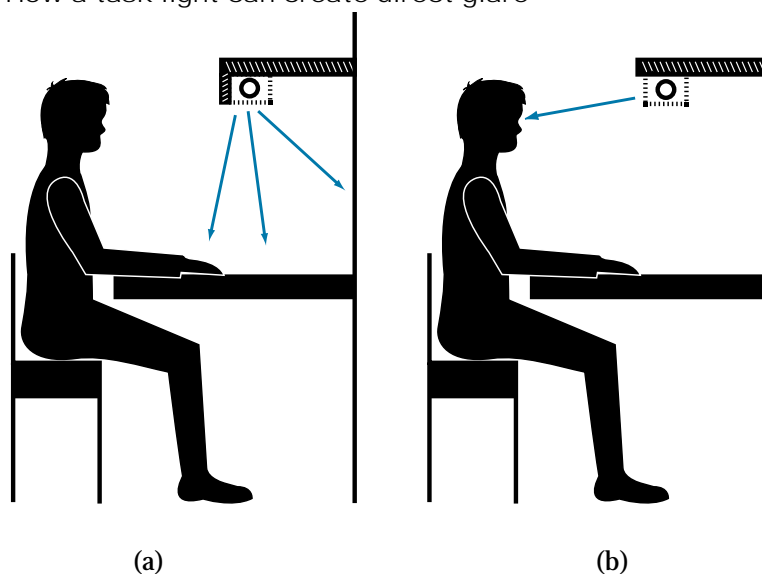

A task light can create direct glare if it is not properly shielded from the direct view of the worker. The lamp in the task light in Figure 2a is blocked from direct view by an opaque housing or by the lip of the shelf. If nothing blocks the light from this angle, or if the task light is mounted too high on the partition, direct glare will result, as illustrated in Figure 2b.

**4. Luminaires with optics that redirect light.** These luminaires are designed to refract (bend) light in directions that are less likely to produce reflected glare and veiling reflections. They include luminaires with a “batwing” lens or a plastic lens coated with a batwing-distribution film. A batwing lens has prism-shaped ribs that are oriented perpendicular to the length of the lamp to refract the light sideways along the length of the desk rather than forward toward the worker (see Figure 3).

**5. Luminaires with optics that both redirect light and mask lamp brightness.** These luminaires combine batwing optics with a mechanism that partially masks or diffuses the light. They include luminaires that use a batwing lens and either a thin diffuser overlay or an opaque strip that blocks light at the offending angles (see Figure 4). This strategy reduces reflected glare and veiling reflections both by refracting the light and by masking or diffusing the image of the bright lamp.

The various methods of reducing reflected glare and veiling reflections all reduce *luminaire efficiency*, because some of the light from the lamps is absorbed by the mechanism that blocks, diffuses, or redirects the light. However, the gain in visual performance that a good optical system provides may compensate for this efficiency sacrifice.

### When should portable task lights be used?

Portable task lights often are brought into an office when workers feel that the existing illuminance is inadequate or when the workstation does not have a shelf. They are more flexible than under-shelf luminaires because they can be moved around the office and can be aimed by the user. Their disadvantages include taking up space on the work surface, greater susceptibility to theft, the annoyance of exposed electrical cords, and non-uniform illuminance distributions.

Under-shelf luminaires from categories 3, 4, and 5 usually are preferable to portable task lights for most office applications because they produce more uniform illuminance distributions over a wider area. However, in many industrial applications, the flexibility of portable lamps makes them preferable. For example, someone working on computer circuit boards may need more light than an under-shelf product can provide. An adjustable desk lamp can be positioned very close to the task and aimed at an angle that maximizes visibility. Some portable products incorporate a magnifying glass, which can be very helpful for some tasks.

### What types of portable task lights are available?

Portable task lights can be categorized by the type of lamp (incandescent or fluorescent) and the type of light distribution (symmetrical or asymmetrical). The light from incandescent and halogen incandescent lamps emanates from a small area, which makes it easy to direct the light with reflectors, but can

**Figure 3**  
A luminaire with a batwing lens that redirects light

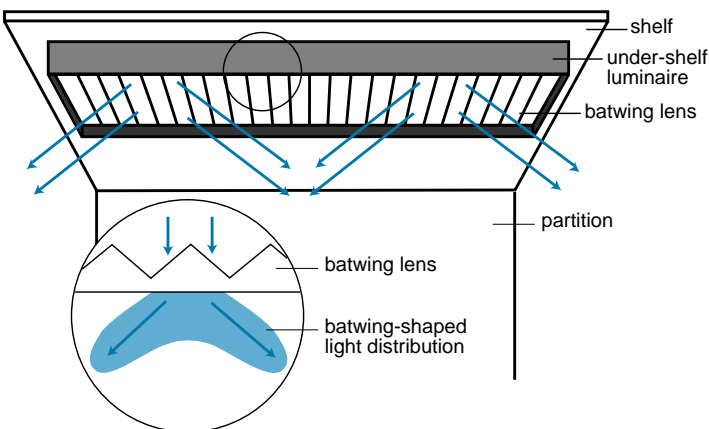

The batwing-distribution lens reduces glare and veiling reflections by directing light sideways rather than forward toward the worker. Each prism (see inset) refracts light to produce a batwing-shaped light distribution.

**Figure 4**  
A luminaire with a batwing lens and an opaque strip

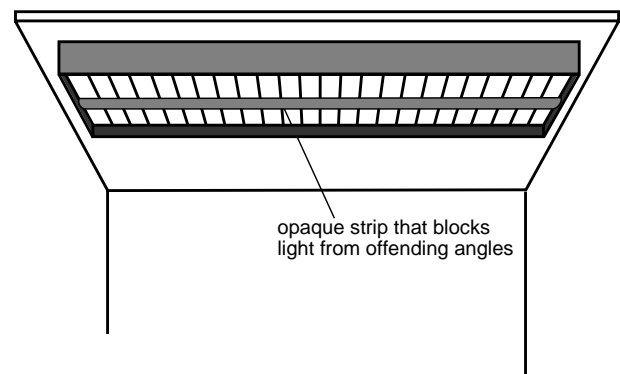

The bright image of the fluorescent lamp is obscured by an opaque strip. This design further reduces reflected glare and veiling reflections.

result in very sharp shadows on the task and very bright reflections from specular tasks or desktops. Incandescent lamps are less energy efficient than fluorescent lamps and can become extremely hot.

Fluorescent lamps used in portable task lights include compact twin-tube and quad-tube, circline, and T5 linear and long twin-tube fluorescent lamps. Light emanates from the entire lamp tube, resulting in more diffuse illuminance than that provided by a small incandescent lamp. Fluorescent lamps create diffuse shadows, as shown in Figure 5. Fluorescent task lights usually have a higher first cost than incandescent task lights, but over time are less expensive to operate because the lamps last longer and use approximately one-third of the energy that incandescent lamps of comparable light output use.

To prevent reflected glare, portable task lights should be positioned to one side of a reading task, rather than at the back of the desk. When aiming the task light, the bare lamp should not be directly visible to the worker (or to neighboring workers), or it will produce direct glare. Products with an asymmetrical distribution can cast light sideways without the need to tilt the head of the lamp (which may cause direct glare). The bare lamp can cause distracting reflections on visual display terminal (VDT) screens, and so should be shielded from a direct line of sight to these devices. Place the unit on the left side of the desk for right-handed workers (and on the right for left-handed workers) to avoid casting a shadow on the task from the person's writing hand.

### How can task lighting maximize energy savings?

First, the general lighting should be reduced when task lighting is added. Otherwise, energy use would increase.

Second, select task lights that have energy-efficient components. Look for the following features:

**Lamp type.** Select fluorescent rather than incandescent lamps wherever possible (see Figures 6 and 7). For under-shelf luminaires that use either a 3- or 4-foot linear fluorescent lamp, the following lamp types are available, ranked from highest to lowest efficacy:

- T8
- T12
- Old-technology T8 (preheat)

For luminaires that use small lamps, including portable task lights and category 3 under-shelf luminaires, fluorescent lamp options include:

- Compact twin-tube and quad-tube
- T5 long twin-tube
- Linear T5 (preheat)
- Circline

Incandescent and halogen incandescent lamps also are available for these luminaires, but are less efficient than any of the fluorescent lamps. *Preheat* linear fluorescent lamps often have short lamp life, limited color selection, and poor ballast efficiency so they should be avoided if *rapid-start* or *instant-start* fluorescent lamps are available.

Figure 5  
Shadows from incandescent and fluorescent lamps

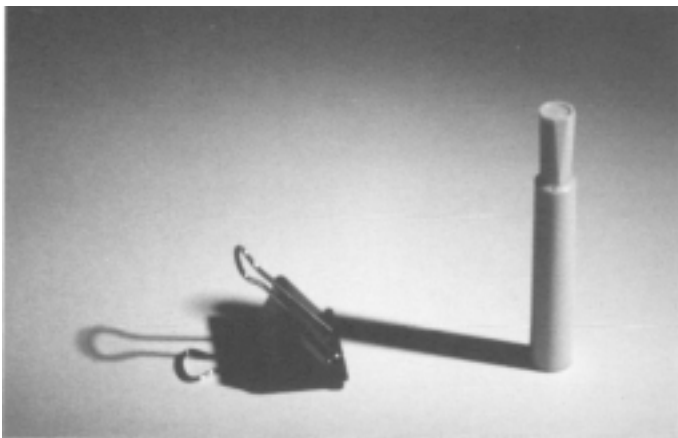

This photo shows distinct shadows cast by objects illuminated by an incandescent lamp.



The light from a fluorescent lamp emanates from a larger area, resulting in diffuse shadows.



**Ballast type.** Electronic ballasts are more energy efficient than magnetic ballasts because they operate lamps at high frequencies (above 20,000 hertz). High-frequency operation also reduces flicker and noise. Electronic ballasts are either instant start or rapid start; instant-start operation is more energy efficient, but may reduce lamp life. *Total harmonic distortion (THD)* varies widely for electronic ballasts. Most electronic ballasts for 4-foot lamps have THD below 20 percent. Some electronic ballasts for compact fluorescent lamps have THD in excess of 100 percent.

Energy efficiency varies widely among magnetic ballasts. Rapid-start ballasts are more efficient than preheat ballasts. For 4-foot lamps, rapid-start ballasts are available with an electronic component that disconnects the electrode-heating voltage during lamp operation (these are called cathode-disconnect ballasts or low-frequency electronic ballasts). These are the most efficient magnetic ballasts for 4-foot lamps, but they may reduce lamp life. *Power factor* also affects ballast performance. High-power-factor ballasts are available for all fluorescent lamp types and are preferable to normal-power-factor or low-power-factor ballasts for most applications.

Magnetic ballasts emit a low level of noise that usually is masked by the ambient noise in an office. Magnetic ballasts for compact fluorescent lamps sometimes emit a high-pitched noise that can be heard by individuals with sensitive hearing. This noise may be minimized by the design of the luminaire.

**Controls.** There are two control strategies that can increase the energy savings that task lighting can provide.

- Occupancy sensors
- Dimming controls

Some task lights are available with built-in occupancy sensors that turn off the light when no motion is detected. Usually, the interval after which the sensor turns off the light is adjustable. The added energy savings often pay for the increased cost.

Dimming controls provide a way for workers to adjust the amount of light to meet their needs. Dimming controls for incandescent lamps are inexpensive, and incandescent lamp life increases if dimmers are used.

Dimming fluorescent lamps is more expensive than dimming incandescent lamps because the preferred method for dimming fluorescent lamps is to use electronic ballasts with special dimming controls. These ballasts can dim lamps without significantly decreasing

lamp life. As an inexpensive option, some manufacturers offer a preheat ballast with a standard dimming control that is designed for incandescent lamps. This approach should be avoided because it saves little energy and can reduce both lamp and ballast life. Dimmers for incandescent lamps never should be used with ballasts that operate fluorescent lamps.

Alternatives to dimming include luminaires that contain two lamps that are switched independently to provide two light levels, and luminaires containing ballasts that provide two or three light levels.

**Figure 6**

Some incandescent and fluorescent lamps that are used in task lights

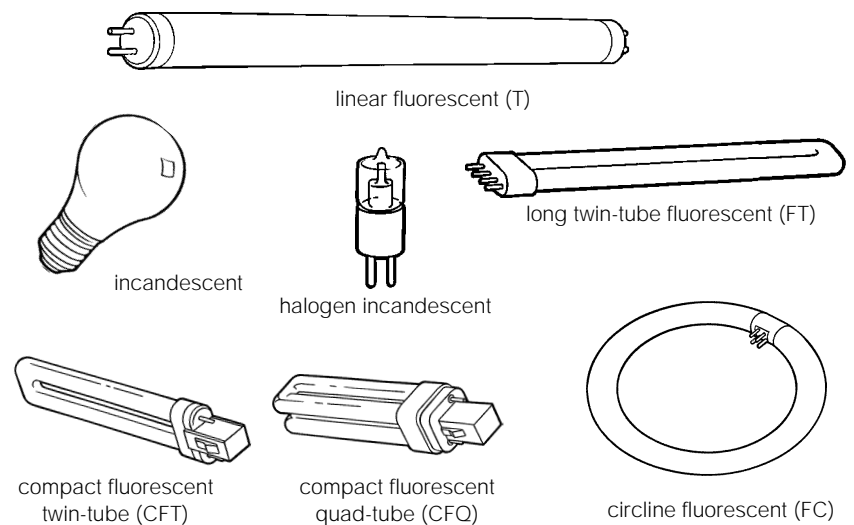

The National Electrical Manufacturers Association (NEMA) designations for fluorescent lamp types are given in parentheses. Lamps are not drawn to scale.

**Figure 7**

Diameters of linear fluorescent lamps

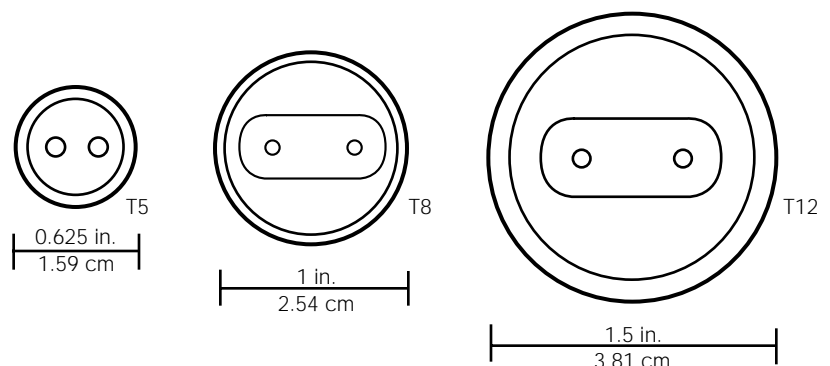

The "T" designation in fluorescent lamp nomenclature stands for tubular. The number immediately following the "T" represents the diameter of the lamp in eighths of an inch. Lamps are drawn at actual size.

## What other factors should be considered when selecting task lights?

The lamp's *correlated color temperature* and *color rendering index* are important in making a task lighting installation acceptable to employees. Incandescent lamps have a "warm" correlated color temperature (CCT) ranging from 2700 K to 3200 K. The CCT of lamps in task lights should match the CCT of the general lighting, to avoid an incongruous color appearance. CCT options for fluorescent lamps include 2700, 3000, 3500, and 4100 K.

The color rendering index (CRI) of a lamp describes its effect on the color appearance of partition and desk surface finishes, work materials, and skin tones. CRIs for fluorescent lamps range from a low of 52 for a warm white fluorescent lamp to over 90 for some deluxe rare-earth phosphor lamps. Incandescent lamps have CRIs greater than 95. In offices, the CRI should be 70 or greater for most applications and greater than 80 where excellent color rendering is desired.

Task lighting cost, quality, and availability vary widely. NLRIP recommends that the specifier inspect task lighting options firsthand. Installing a sample in a workstation allows the specifier to experience its visibility, comfort, noise, and other performance characteristics.

## Glossary

---

**color rendering index (CRI)** A method for describing the effect of a light source on the color appearance of objects being illuminated, with a CRI of 100 representing the reference condition (and thus the maximum CRI possible). In general, a lower CRI indicates that some colors may appear unnatural when illuminated by the lamp.

**correlated color temperature (CCT)** A description of the color appearance of a light source in terms of its warmth or coolness. The CCT relates the color appearance of the light emitted by a lamp to the color appearance of a reference material heated to a high temperature (measured on the Kelvin scale, abbreviated K). As the temperature rises, the color appearance shifts from yellow to blue. Thus, lamps with a low CCT (3000 K or less) have a yellow-white color appearance and are described as "warm"; lamps with a high CCT (4000 K and higher) have a blue-white color appearance and are described as "cool."

**illuminance** The amount of light that reaches a surface. Illuminance is measured in footcandles (lumens/square foot) or lux (lumens/square meter). One footcandle equals 10.76 lux, although for convenience the IESNA uses 10 lux as the equivalent.

**instant-start** A method of starting fluorescent lamps in which the voltage that is applied across the electrodes to strike the electric arc is up to twice as high as it is with other starting methods. The higher voltage is necessary because the electrodes are not heated prior to starting. This method starts the lamps without flashing; it is more energy efficient than rapid or preheat starting, but results in greater wear on the electrodes during starting. The life of instant-start lamps that are switched on and off frequently may be reduced by as much as 25 percent relative to rapid-start operation. However, for longer burning cycles (such as 12 hours per start), there may be no difference in lamp life for different starting methods.

**luminaire efficiency** The ratio of the light emitted by a luminaire to the light emitted by the lamp or lamps within it. Components of a luminaire such as reflectors and diffusers absorb some of the light from the lamp(s). A highly efficient luminaire emits most of the light that the lamp(s) emits.

**power factor** A measure of how effectively a ballast converts current and voltage into usable power to operate the lamps. A power factor of 0.9 or greater indicates a high-power-factor ballast.

**preheat** A method of starting fluorescent lamps in which the electrodes are heated before a switch opens to allow a starting voltage to be applied across the lamp. With preheat starting, the lamp flashes on and off for a few seconds before staying lit, because several starting attempts may be necessary to establish the electric arc across the lamp electrodes. Often, the luminaire's start button must be held down until the lamp lights. Preheat ballasts are less energy efficient than rapid-start or instant-start ballasts.

**prismatic lens** An optical component of a luminaire that is used to distribute the emitted light. It is usually a sheet of plastic with a pattern of pyramid-shaped refracting prisms on one side. Most ceiling-mounted luminaires in commercial buildings use prismatic lenses.

**rapid-start** A method of starting fluorescent lamps in which the ballast supplies voltage to heat the lamp electrodes for 1 to 2 seconds prior to starting and, in most cases, during lamp operation. A rapid-start system starts smoothly, without flashing.

**total harmonic distortion (THD)** A measure of the degree to which a sinusoidal wave shape is distorted by harmonic wave forms, with higher values of THD indicating greater distortion. Electrical devices, such as computers and fluorescent lighting systems, can send harmonic wave forms at many frequencies back onto the power supply line, thereby distorting the current wave shape. For 4-foot lamps, the American National Standards Institute (ANSI) recommends a THD limit of 32 percent, but some electric utilities only provide financial incentives for ballasts that produce less than 20 percent THD. Ballasts that produce less than 10 percent THD are available for installations with critical power requirements.

## Resources

Illuminating Engineering Society of North America. 1993. *Lighting handbook: Reference & application*. M. Rea, ed. New York, NY: Illuminating Engineering Society of North America.

Illuminating Engineering Society of North America. Office Lighting Committee. 1993. *American national standard practice for office lighting*, ANSI/IESNA RP-1-1993. New York, NY: Illuminating Engineering Society of North America.

Illuminating Engineering Society of North America. Office Lighting Committee. Subcommittee on Visual Display Terminals. 1989. *IES recommended practice for lighting offices containing computer visual display terminals*, IES RP-24-1989. New York, NY: Illuminating Engineering Society of North America.

Steelcase Incorporated. 1989. *Office environment index: 1989 summary report*. Grand Rapids, MI: Steelcase Inc.

### NLPIP Publications

*Guide to performance evaluation of efficient lighting products, 1991*

#### **Specifier reports:**

*Electronic ballasts, 1991*

*Power reducers, 1992*

*Specular reflectors, 1992*

*Occupancy sensors, 1992*

*Parking lot luminaires, 1993*

*Screwbase compact fluorescent lamp products, 1993*

*Cathode-disconnect ballasts, 1993*

*Exit signs, 1994*

#### **Lighting answers:**

*T8 fluorescent lamps, 1993*

*Multilayer polarizer panels, 1993*

## Program Sponsors

Hydro-Québec

Iowa Energy Center

Lighting Research Center

New England Electric Companies

New England Power Service Company, New England Power Company, Massachusetts Electric Company, The Narragansett Electric Company, Granite State Electric Company

New York State Energy Research and Development Authority

Northern States Power Company

Southern California Edison Company

PSI Energy

United States Department of Energy

United States Environmental Protection Agency

Wisconsin Center for Demand-Side Research

NATIONAL  
LIGHTING  
PRODUCT  
INFORMATION  
PROGRAM

## LightingAnswers

### Task Lighting for Offices

Volume 1, Number 3

April 1994

Authors: Robert Wolsey and Naomi Miller

Technical Consultant: Mitchell Kohn

Technical Review: Mark Rea

Principal Investigator: Robert Davis

Project Director: Russell Leslie

Editorial Review: Amy Fowler

Production: Martha Guilfoyle

Graphics: Martha Guilfoyle and Bruce Kaiser

Photography: Robert Strobel

Copyright © 1994 Rensselaer Polytechnic Institute. All rights reserved. No portion of this publication or the information contained herein may be duplicated or excerpted in any way in any other publications, databases, or any other medium without express written permission of the publisher.

Making copies of all or part of this publication for any purpose other than for undistributed personal use is a violation of United States copyright laws.

It is against the law to inaccurately present information extracted from *Lighting Answers* for product publicity purposes. Information in these reports may not be reproduced without permission of Rensselaer Polytechnic Institute.

ISSN 1069-0050

*For publications ordering information, write or fax:*

Lighting Research Center  
Rensselaer Polytechnic Institute  
Troy, NY 12180-3590  
Fax (518) 276-2999

**Rensselaer**



*Lighting Answers* is printed on a paper that is made from 50% recycled fiber, including 10% post-consumer waste.

## LightingAnswers

*Lighting Answers* is a serial publication that is designed to complement the National Lighting Product Information Program's (NLPIP) other serial publication, *Specifier Reports*. Each issue of *Lighting Answers* presents information in one of three formats: some issues present educational information about a specific topic that is of concern to lighting professionals; some issues present a summary of available information about a particular technology in an educational format with no testing; and other issues present information about a new or special technology on which NLPIP has performed some limited testing. For this issue of *Lighting Answers*, NLPIP has summarized available information about task lighting for offices; no testing was conducted.